

C
10.5"
267



Hannay Reels®
The reel leader.

Firefighting Reels

- | Preconnect or Storage | No Draining, Stacking, or Dragging | All Sizes and Capacities |
- | Efficient Use of Vehicle Space | Increased Hose Capacity | Faster Clean-up | ARFF |



**You Can't Buy
A Better Reel.**

Family owned and operated since 1933

Contents

Reel Type	I.D. Hose Sizes	Page
How to Specify Hannay Reels		3
Manual or Power Rewind Reels		
Series F4000	3/4" or 1"	4
Series F4100	3/4" or 1"	5
Series F	3/4" or 1"	6-7
Series SF	3/4" or 1"	8-9
Twin Fire Reel Conversion Kit		10
Series FF - Booster Hose	1-1/4" or 1-1/2"	10-11
Collapsible Hose	1-1/2" or 1-3/4"	
Series F7100 - Dual Hose	3/4" – 1-1/2"	12-13
Swing-Out Reel - Single Hose	1" – 1-1/2"	14-15
Dual Hose	1" – 1-1/2"	
Manual Rewind Reels		
Series F3100/FF3600 - Booster Hose	3/4" – 1-1/2"	16-17
Collapsible Hose	1" – 1-3/4"	
Manual or Power Rewind Reels - Large Diameter		
Series LD Reels and Spools	1-1/2" – 6"	18-19
Mercedes and Niedner Capacities		20
Hannay Reels Versatility		21
Hannay Reels Policies – Our Guarantee, Service Policy, Paint Notice, Return Goods Policy		22
Hannay Reels Spec Worksheet		23

Top performance. Extreme conditions. Hannay Reels.

Safety and quick response time are critical when it comes to fighting fires. Our reels make payout and pickup quicker so you can work more efficiently and effectively when every second counts. That's why Hannay Reels is the #1 reel company specified by OEMs and professionals worldwide, based on product reliability, ease of use, and long life. When it comes to keeping your crew and your community safe, you can trust Hannay Reels.

Attention Truck Committees and Specifiers of Fire Apparatus

Products shown and described in this catalog are suggested models for broad use applications throughout the firefighting industry. All models can be assembled to dimensionally fit your unique applications and space requirements, and all our components are designed for multiple configurations.

For special orders, contact your Hannay dealer or call our Inside Sales Group.



Types of reels:

Booster Hose Reels – Quick first-attack for small fires or while larger volume hoses are being set up.

LD (Large Diameter) Reels – Reels for long lengths of 1-1/2" to 6" collapsible hose.

Dual Agent Reels – For firefighting with foam.

NEW Swing-Out Reels – For aircraft rescue firefighting applications.

Mounting Hole Sizes

Pressed Frame Reels and Channel Framed Reels	7/16" wide x 7/8" long slot running left to right
Series 4000 Reels	13/32" round holes
Series LD Reels	5/8" round holes

How to Specify **Hannay Reels**

Optional Location of Components

Location of the inlet, outlet riser, and rewind mechanism can be varied to meet your requirements and **must be specified on your order**. The drawings below show the component locations. Unless otherwise specified, most reels will be shipped as **Right Top Rewind** with the inlet, outlet riser, and rewind mechanism on the operator's right.

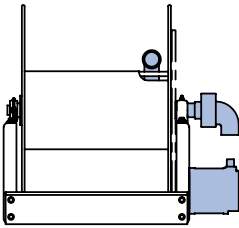

RT – Right Top Rewind

Reels have the inlet, outlet riser, and rewind mechanism on the operator's right. Hose unwinds from the top of the reel.

Standard – Always look at your reel from this position to determine right-hand or left-hand.

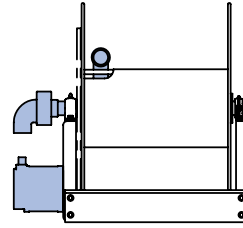

LT – Left Top Rewind

Reels have the inlet, outlet riser, and rewind mechanism on the operator's left. Hose unwinds from the top of the reel.

Standard for 1500, 1800, 2000 & 4000 Series reels.

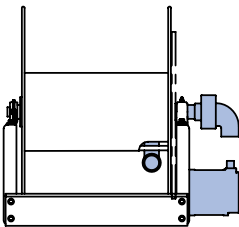

RB – Right Bottom Rewind

Reels have the inlet, outlet riser, and rewind mechanism on the operator's right. Hose unwinds from the bottom of the reel.

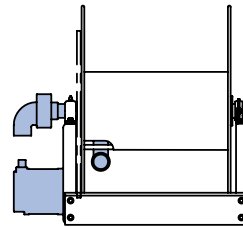

LB – Left Bottom Rewind

Reels have the inlet, outlet riser, and rewind mechanism on the operator's left. Hose unwinds from the bottom of the reel.

Note: Use component location initials as suffix after model number (ie; EF32-23-24 **RT**)

Optional Motor Locations

Electric rewind motors can be installed in any of the positions shown in these drawings. The Bottom Rear position is standard. The motor is installed inside the frame on Model ESF reels, which are designed for installation in restricted space.

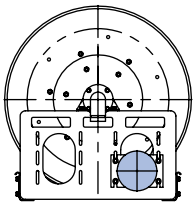

Bottom Rear (Standard)

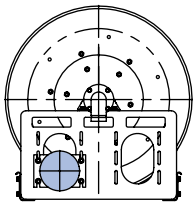

Bottom Front

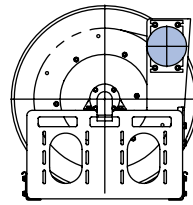

Elevated 2 O'clock (REF Reels)

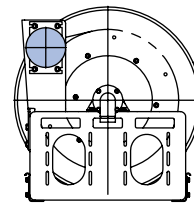

Elevated 10 O'clock (REF Reels)

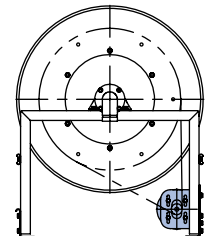

Inboard (ESF Reels)

Optional Auxiliary Rewind Positions

Horizontal ring and pinion gear crank rewind mechanism is the standard configuration.

Optional positions include vertical and 30° above centerline, as shown in these drawings. Both are available at extra cost and **must be specified**.

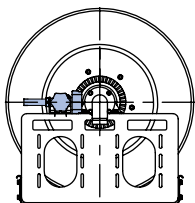

Horizontal (Standard)

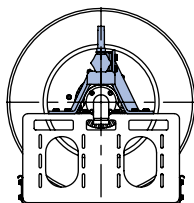

Vertical

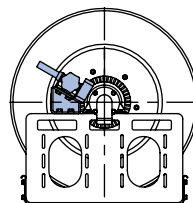

30° Angle

Optional Roller Positions

Optional roller assembly mounting kits, up to 2 of either, can be mounted per reel. Consult factory, and indicate installation location – front or rear of reel.

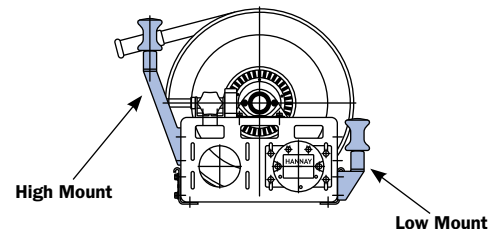

Series F4000 | For Booster Hose

• **Compact Reels**

To handle single 3/4" or 1" I.D. hose.

- Choose direct crank rewind (removable) or chain and sprocket drive powered by electric, hydraulic or compressed air motor.
- Power rewind supplied with strap brake.
- Direct crank rewind supplied with cam-lock brake.
- Standard inlet: 90° ball bearing swivel joint, 1" female NPT threads.
- Standard outlet: 1" male NST threads (1.375" x 8 threads per inch).
- Consult factory for other sizes and/or threads.
- Standard inlet, outlet riser and hub assembly are steel (also available in stainless steel).
- Rollers and roller mounting brackets are accessory items. Specify roller position.
- Pressures to 1000 psi (69 bar).
- Temps from -25°F to +250°F (-32°C to +121°C).
- Consult factory for other pressures and temperatures.



Electric motor Standard configuration shown

CAUTION: F4000/F4100 Series reels **not** recommended for use with Niedner hose. See page 20.

PARTS DRAWING – ISO 68



Optional External Mounting Brackets

Part No. 9906.0025.
Add 2-1/2" to the X dimensions shown in the chart.

Model Number <small>For power rewind see Note 5</small>	Hose Capacity of Reel feet m			Approx. Weight Crank Rewind lb. kg <small>see Note 3</small>			Reel Dimensions*** In. mm						
	I.D. in. mm	3/4 19	1 25	NET	UPS/ FedEx SHIP WT.	Freight SHIP WT.	A	B	E CRANK	E POWER	F CRANK	F POWER	X
	O.D. in. mm	1-9/32 33	1-1/2 38										
F4018-17-18		50 15	35 11	36 16	80* 36	71 32	15 381	10 254	16.5 419	19 483	27.75 705	20.5 521	13.5 343
F4024-17-18		100 30	50 15	46 21	83* 38	81 37	21 533	16 406	16.5 419	19 483	33.75 857	26.5 673	19.5 495
F4030-17-18		150 46	75 23	57 26	110* 50	92 42	27 686	22 559	16.5 419	19 483	39.75 1010	32.5 826	25.5 648
F4038-17-18		200 61	100 30	70 32	- -	125 57	35 889	30 762	16.5 419	19 483	47.75 1213	40.5 1028	33.5 851

Notes:

1. Specifications subject to change.
2. Upon request, reels can be supplied with drum lengths other than shown and with disc sizes in other diameters.
3. Weights shown in chart are for crank rewind models. ADD these amounts for power rewind models. (does not apply to FedEx or UPS):

	Net lbs./kg	Ship lbs./kg
Electric	18/8.2	18/8.2
Hydraulic	15/6.8	15/6.8
Air	15/6.8	15/6.8
4. Dimension "F" is the overall length of standard model reels. On crank rewind models, the dimension shown is with the crank in rewind position. Reels require 3-1/2" clearance to remove crank handle.
5. When ordering power rewind models, prefix model number with:
 - A** = Air Rewind – supplied with control valve and 18" air hose.
 - E** = Electric Rewind (1/3 HP) – 12v and 24v DC rewind reels supplied with switch and solenoid. 115v AC rewind reels are not supplied with switch, but can be ordered separately.
 - HD** = Hydraulic Rewind – not supplied with control valve.
6. **Be sure to check dimensions and weights prior to ordering.**
7. Some roller options may prohibit the use of our molded chain guard.

NOTICE: A flexible connector must be used between the inlet pipe and the inlet swivel joint.
*Dimensional weight applies when shipped as a parcel package (via FedEx or UPS Ground).
*** X, Y indicate mounting holes.

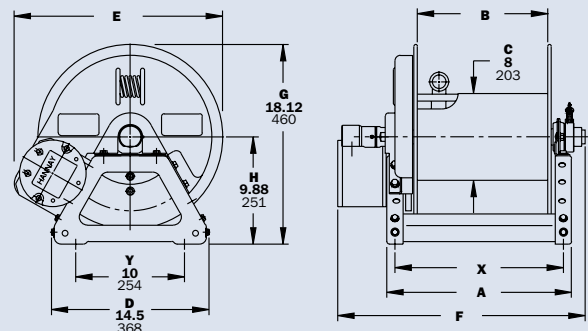

Series F4100

To handle single 3/4" or 1" I.D. hose.

- Lightweight, compact reels designed for long lengths of hose in manual and power rewind.
- Gear-driven crank rewind handle is removable.
- Chain and sprocket drive powered by electric, hydraulic or compressed air motor.
- Gear-driven crank rewind, adjustable pinion brake.
- Standard inlet: 90° ball bearing swivel joint, 1" female NPT threads.
- Standard outlet: 1" male NST threads.
- Optional rollers: Specify roller position when ordering.
- Pressures to 1000 psi (69 bar).
- Temperatures from -25°F to +250°F (-32°C to +121°C).
- Consult factory for other pressures and temperatures.



Electric rewind with gear-driven crank rewind shown

CAUTION: F4000/F4100 Series reels **not** recommended for use with Niedner hose. See page 20.

PARTS DRAWING – ISO 216

Model Number For power rewind see Note 5	Hose Capacity of Reel feet m			Approx. Weight Crank Rewind lb. kg see Note 3		Reel Dimensions*** in. mm					
	I.D. in. mm	3/4 19	1 25	NET	SHIP	A	B	E CRANK	E POWER	F	X
	O.D. in. mm	1-9/32 33	1-1/2 38								
F4118-17-18		50 15	35 11	62 28	97 44	15 381	10 254	18 457	20.5 521	21.5 546	7.5 190
F4124-17-18		100 30	50 15	72 33	107 49	21 533	16 406	18 457	20.5 521	27.5 699	13.5 343
F4130-17-18		150 46	75 23	83 38	118 54	27 686	22 559	18 457	20.5 521	33.5 851	19.5 495
F4138-17-18		200 61	100 30	96 44	131 59	35 889	30 762	18 457	20.5 521	41.5 1054	27.5 698

Notes:		<p>5. When ordering power rewind models, prefix model number with:</p> <p>A = Air Rewind – supplied with control valve and 18" air hose.</p> <p>E = Electric Rewind (1/3 HP) – 12v and 24v DC rewind reels supplied with switch and solenoid. 115v AC rewind reels are not supplied with switch, but can be ordered separately.</p> <p>HD = Hydraulic Rewind – not supplied with control valve.</p> <p>6. Be sure to check dimensions and weights prior to ordering.</p>												
1. Specifications subject to change.														
2. Upon request, reels can be supplied with drum lengths other than shown.														
3. Weights shown in chart are for crank rewind models. ADD these amounts for power rewind models:														
	<table border="1"> <tr> <th></th> <th>Net lbs/kg</th> <th>Ship lbs/kg</th> </tr> <tr> <td>Electric</td> <td>18/8.2</td> <td>18/8.2</td> </tr> <tr> <td>Hydraulic</td> <td>15/6.8</td> <td>15/6.8</td> </tr> <tr> <td>Air</td> <td>15/6.8</td> <td>15/6.8</td> </tr> </table>			Net lbs/kg	Ship lbs/kg	Electric	18/8.2	18/8.2	Hydraulic	15/6.8	15/6.8	Air	15/6.8	15/6.8
	Net lbs/kg		Ship lbs/kg											
Electric	18/8.2	18/8.2												
Hydraulic	15/6.8	15/6.8												
Air	15/6.8	15/6.8												
4. Dimension "F" is the overall length of standard model reels.														
<p>NOTICE: A flexible connector must be used between the inlet pipe and the inlet swivel joint.</p> <p>*** X, Y indicate mounting holes.</p>														

Dimensions: E, G=18.12 (460), H=9.88 (251), Y=12.5 (318), D=15.5 (394)

Dimensions: B, C=8 (203), X, A, F

Series **F/SBF** | For Booster Hose

To handle 3/4" or 1" I.D. hose.

- Standard booster hose reel is steel, painted graphite. Aluminum or stainless steel construction is also available.
- Super Booster® (SBF) polished aluminum construction reel weighs up to 30% less than standard booster reel. Prefix complete model number with "SB" when ordering. See Note 6 on page 7.
- Gear-driven crank rewind is standard. Choose chain and sprocket drive powered by electric, hydraulic or compressed air motor.
- Pinion brake standard.
- Standard inlet: 1" 90° ball bearing swivel joint with 1" female NPT threads.
- Standard outlet: 1" male NST threads. (1.375" x 8 threads per inch.)
- Consult factory for other sizes and/or threads.
- Standard inlet, outlet riser, and hub assembly are steel (also available in stainless steel).
- Rollers and roller mounting brackets are accessory items. Specify roller position.
- Pressures to 1000 psi (69 bar).
- Temperatures from -25°F to +250°F (-32°C to +121°C).
- Consult factory for reels to operate at other pressures and temperatures.



Shown with optional red finish and optional roller and spool assembly

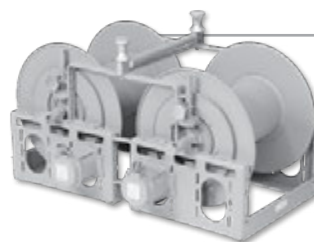

Twin Fire Reel Conversion Kit is also available. Refer to page 10.

CAUTION: When using Niedner hose, a special riser and/or larger drum diameter is required.

See chart for capacity on page 20, or consult factory.

Hub Assembly Options

The hub assembly is the heart of the hose reel. It includes the outlet riser, the reel axle, and the threaded inlet to which the swivel joint is attached. The swivel joint permits the reel to rotate freely while connected to the fluid source.

The outlet riser is engineered to conform to the contour of the drum so the hose lies smoothly against the drum without kinking. Smooth interior surfaces are flow-contoured for unrestricted flow and minimal pressure loss through the reel.

A 2-way flow hub assembly is available on certain models as an option. On this assembly, the reel axle is threaded on both ends so the swivel joint can be attached at either end to match piping. A pipe cap is supplied to seal the opposite end.

Standard Hub Assembly

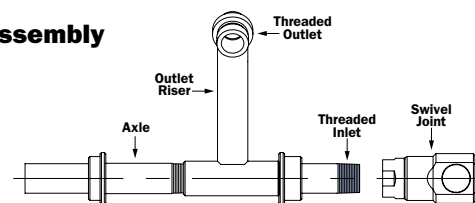

Standard Hub Assembly with Optional Flanged Riser

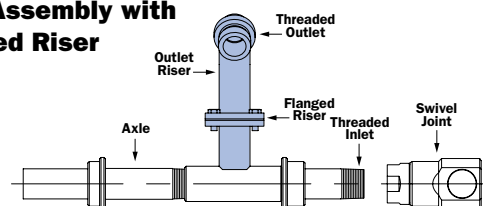

Optional 2-Way Hub Assembly

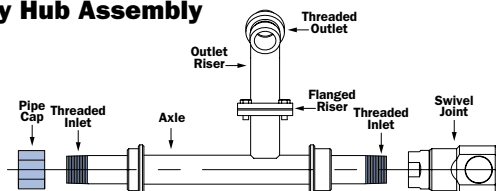

PARTS DRAWING: SERIES F – ISO 84; SERIES SBF SUPER BOOSTER® – ISO 122

Model Number <small>For power rewind see Note 5</small>	Hose Capacity of Reel feet m			Approx. Weight Crank Rewind lb. kg <small>see Note 4</small>				Reel Dimensions*** In. mm									
	I.D. in. mm	3/4 19	1 25	STEEL		ALUMINUM <small>see Note 6</small>		A	B	D	E	F CRANK	F POWER	G	H	X	Y
	O.D. in. mm	1-9/32 33	1-1/2 38	NET	SHIP	NET	SHIP										
*F32-19-21	175 53	85 26	102 46	144 65	80 36	122 55	29.5 749	24 610	20.5 521	21.62 549	34.25 870	34.38 873	21.5 546	12.12 308	12.12 308	21.5 546	16.75 425
*F24-23-24	150 46	125 38	92 42	134 61	75 34	117 53	21 533	15.5 394	20.5 521	23 584	25.75 654	25.88 657	23.5 597	12.12 308	12.12 308	13 330	16.75 425
*F30-23-24	225 68	200 61	105 48	147 67	82 37	124 56	27.5 699	22 559	20.5 521	23 584	32.25 819	32.38 822	23.5 597	12.12 308	12.12 308	19.5 495	16.75 425
F38-23-24	300 91	250 76	120 54	162 73	92 42	134 61	35 889	29.5 749	20.5 521	23 584	39.75 1010	41.75 1060	23.5 597	12.12 308	12.12 308	27 686	16.75 425
F28-25-26	275 84	175 53	113 51	155 70	87 39	129 59	25.5 648	20 508	25.5 648	24.75 629	30.25 768	32.25 819	27.88 708	15.5 394	15.5 394	17.5 445	21.75 552
F34-25-26	350 107	250 76	126 57	168 76	93 42	135 61	31.5 800	26 660	25.5 648	24.75 629	36.25 921	38.25 972	27.88 708	15.5 394	15.5 394	23.5 597	21.75 552
*F16.5-30-31	175 53	125 38	100 45	150 68	80 36	130 59	13.5 343	8 203	25.5 648	28.75 730	18.25 464	18.38 467	29.88 759	15.5 394	15.5 394	5.5 140	21.75 552
*F20-30-31	250 76	150 46	107 49	157 71	83 38	133 60	17 432	11.5 292	25.5 648	28.75 730	21.75 552	21.88 556	29.88 759	15.5 394	15.5 394	9 229	21.75 552
F24-30-31	350 107	250 76	113 51	163 74	87 39	137 62	21 533	15.5 394	25.5 648	28.75 730	25.75 654	27.75 705	29.88 759	15.5 394	15.5 394	13 330	21.75 552
F28-30-31	-	300 91	121 55	171 78	90 41	140 64	25.5 648	20 508	25.5 648	28.75 730	30.25 768	32.25 819	29.88 759	15.5 394	15.5 394	17.5 445	21.75 552
F34-30-31	-	350 107	134 61	184 83	97 44	147 67	31.5 800	26 660	25.5 648	28.75 730	36.25 921	38.25 972	29.88 759	15.5 394	15.5 394	23.5 597	21.75 552
F20-33-34	300 91	200 61	107 49	157 71	83 38	133 60	16.5 419	11.5 292	31.5 800	31.75 806	21.12 536	23.25 591	33.62 854	17.75 451	9 229	27.75 705	

Notes:

- Specifications subject to change.
- A 2-way flow hub is available at no extra cost and must be specified. Assembly is threaded on both ends so swivel joint can be attached at either end of the reel. A pipe cap seals the opposite end. (See Ordering & Accessory Guide.)
- Upon request, reels can be supplied with drum lengths other than shown and with disc sizes in other diameters.
- Weights shown in chart are for crank rewind models. ADD these amounts for power rewind models:

	Net lbs/kg	Ship lbs/kg
Electric	40/18.1	40/18.1
Hydraulic	20/9.1	20/9.1
Air	20/9.1	20/9.1
- When ordering power rewind models, prefix model number with:
 - A** = Air Rewind – supplied with control valve and 18" air hose.
 - E** = Electric Rewind (1/3 HP)
 - EP** = Electric Rewind (1/2 HP) – 12v and 24v DC rewind reels supplied with switch and solenoid. 115v AC rewind reels are not supplied with switch, but can be ordered separately.
 - HD** = Hydraulic Rewind – not supplied with control valve.
- For polished aluminum reels, prefix complete model number with "SB" (for example: SBEF 32-19-21).
- When installing FH-3 rollers, add 4-1/2" to the "D" dimension.
- Be sure to check dimensions and weights prior to ordering.**

NOTICE: A flexible connector must be used between the inlet pipe and the inlet swivel joint.

*The "F" dimension for these models is shown for 1/3 HP motors. Add 2" to "F" dimension for 1/2 HP motors. The "F" dimension for all other reels is shown for 1/2 HP. Reels handling 175' or more must use 1/2 HP motor. (Use prefix EP when ordering.)

*** X, Y indicate mounting holes.

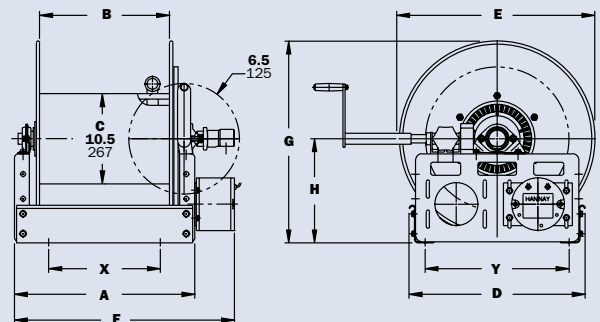

Series **SF/SBSF** | For Booster Hose

• **Inboard Mounted Motor**

To handle 3/4" or 1" I.D. hose.

- Inboard motor location high profile.
- Standard booster hose reel is steel, painted graphite. Aluminum or stainless steel construction is also available.
- Super Booster® (SBSF) polished aluminum construction reel weighs up to 30% less than standard booster reel. Prefix complete model number with "SB" when ordering. See Note 6 on page 9.
- Choose chain and sprocket rewind powered by either electric or compressed air motor.
- Pinion brake standard.
- Standard inlet: 1" 90° ball bearing swivel joint with 1" female NPT threads.
- Standard outlet: 1" male NST threads (1.375" x 8 threads per inch).
- Consult factory for other sizes and/or threads.
- Standard inlet, outlet riser, and hub assembly are steel (also available in stainless steel).
- Rollers and roller mounting brackets are accessory items. Specify roller position.
- Pressures to 1000 psi (69 bar).
- Temperatures from -25°F to +250°F (-32°C to +121°C).
- Consult factory for other pressures and temperatures.

CAUTION: When using Niedner hose, a special riser and/or larger drum diameter is required.

See chart for capacity on page 20, or consult factory.



Standard configuration shown

Hub Assembly Options

The hub assembly is the heart of the hose reel. It includes the outlet riser, the reel axle, and the threaded inlet to which the swivel joint is attached. The swivel joint permits the reel to rotate freely while connected to the fluid source.

The outlet riser is engineered to conform to the contour of the drum so the hose lies smoothly against the drum without kinking. Smooth interior surfaces are flow-contoured for unrestricted flow and minimal pressure loss through the reel.

A 2-way flow hub assembly is available on certain models as an option. On this assembly, the reel axle is threaded on both ends so the swivel joint can be attached at either end to match piping. A pipe cap is supplied to seal the opposite end.

Standard Hub Assembly

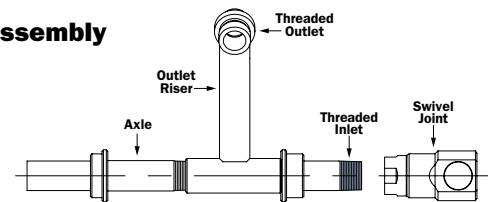

Standard Hub Assembly with Optional Flanged Riser

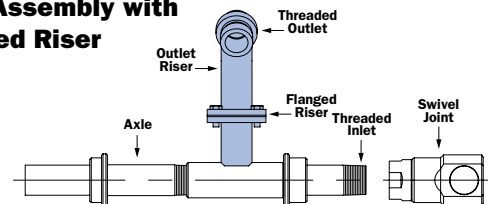

Optional 2-Way Hub Assembly

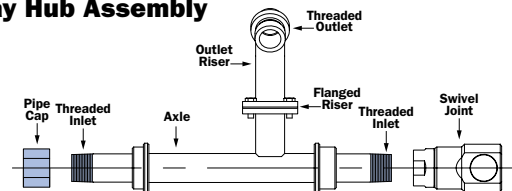

For Booster
Hose |

Series SF/SBSF

• Inboard Mounted Motor

PARTS DRAWING – ISO 220

Model Number For power rewind see Note 5	Hose Capacity of Reel feet m			Approx. Weight Crank Rewind lb. kg see Note 4				Reel Dimensions*** in. mm								
	I.D. in. mm	3/4 19	1 25	STEEL		ALUMINUM see Note 6		A	B	D	E	F	G	H	X	Y
				NET	SHIP	NET	SHIP									
SF32-19-21	175 53	85 26	1 25	102 46	144 65	80 36	122 55	29 737	24 610	20.5 521	21.62 549	34 864	25.12 638	15.75 400	21.5 546	16.75 425
SF24-23-24	150 46	125 38	2 51	92 42	134 61	75 34	117 53	20.5 521	15.5 394	23.5 597	23 584	25.5 648	29.25 743	17.88 454	13 330	19.75 502
SF30-23-24	225 68	200 61	3 76	105 48	147 67	82 37	124 56	27 686	22 559	23.5 597	23 584	32 813	29.25 743	17.88 454	19.5 495	19.75 502
*SF28-25-26	275 84	175 53	4 102	113 51	155 70	87 39	129 59	25 635	20 508	25.5 648	24.75 629	30 762	30.88 784	18.5 470	17.5 445	21.75 552
*SF34-25-26	350 107	250 76	5 127	126 57	168 76	93 42	135 61	31 787	26 660	25.5 648	24.75 629	36 914	30.88 784	18.5 470	23.5 597	21.75 552
SF16.5-30-31	175 53	125 38	4 102	100 45	150 68	80 36	130 59	13 330	8 203	29 737	28.75 730	18 457	35.62 905	21.25 540	5.5 140	25.25 641
SF20-30-31	250 76	150 46	5 127	107 49	157 71	83 38	133 60	16.5 419	11.5 292	29 737	28.75 730	21.5 546	35.62 905	21.25 540	9 229	25.25 641
*SF24-30-31	350 107	250 76	6 152	113 51	163 74	87 39	137 62	20.5 521	15.5 394	29 737	28.75 730	25.5 648	35.62 905	21.25 540	13 330	25.25 641
*SF28-30-31	-	300 91	7 178	121 55	171 78	90 41	140 64	25 635	20 508	29 737	28.75 730	30 762	35.62 905	21.25 540	17.5 445	25.25 641
*SF34-30-31	-	350 107	8 203	134 61	184 83	97 44	147 67	31 787	26 660	29 737	28.75 730	36 914	35.62 905	21.25 540	23.5 597	25.25 641
*SF20-33-34	300 91	200 61	6 152	117 53	167 76	90 41	140 64	16.5 419	11.5 292	31.5 800	31.75 806	21.12 536	38.12 968	22.25 565	9 229	27.88 708

Notes:

- Specifications subject to change.
- A 2-way flow hub is available at no extra cost and must be specified. Assembly is threaded on both ends so swivel joint can be attached at either end of the reel. A pipe cap seals the opposite end. (See Ordering & Accessory Guide.)
- Upon request, reels can be supplied with drum lengths other than shown and with disc sizes in other diameters.
- Weights shown in chart are for crank rewind models. ADD these amounts for power rewind models (does not apply to FedEx or UPS):

	Net lbs/kg	Ship lbs/kg
Electric	40/18.1	40/18.1
Hydraulic	20/9.1	20/9.1
Air	20/9.1	20/9.1
- When ordering power rewind models, prefix model number with:
 - A** = Air Rewind – supplied with control valve and 18" air hose.
 - E** = Electric Rewind (1/3 HP)
 - EP** = Electric Rewind (1/2 HP) – 12v and 24v DC rewind reels supplied with switch and solenoid. 115v AC rewind reels are not supplied with switch, but can be ordered separately.
 - HD** = Hydraulic Rewind – not supplied with control valve.
- For polished aluminum reels, prefix complete model number with "SB" (for example: SBESF32-19-21).
- All frames are rollformed channel, except Super Booster®, which is square tubing.
- Be sure to check dimensions and weights prior to ordering.**

NOTICE: A flexible connector must be used between the inlet pipe and the inlet swivel joint.

* Reels handling 175' or more of 1" must use 1/2 HP motor.

*** X, Y indicate mounting holes.

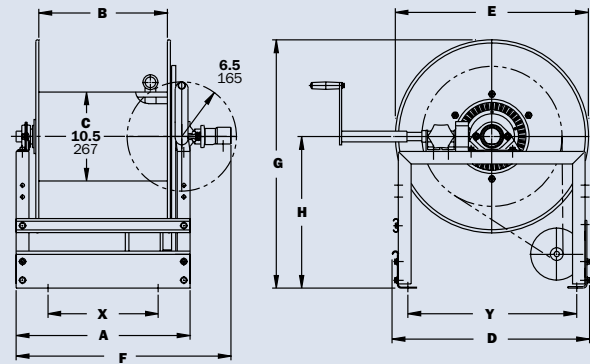

Series **FF/SBFF**

• Large Diameter Booster Hose • Preconnected Collapsible Hose

To handle 1-1/4" or 1-1/2" I.D. booster hose or 1-1/2" or 1-3/4" I.D. collapsible hose.

- Standard booster hose reel is steel, painted graphite. Aluminum or stainless steel construction is also available.
- Super Booster® (SBFF) polished aluminum construction reel weighs up to 30% less than standard booster reel. Prefix complete model number with "SB" when ordering. See Note 6 on page 11.
- Gear-driven crank rewind is standard. Choose chain and sprocket drive powered by electric, hydraulic or compressed air motor.
- Pinion brake standard.
- Standard inlet: 1-1/2" 90° ball bearing swivel joint with 1-1/2" female NPT threads and 2" Victaulic® groove.
- Flanged outlet riser.
- Standard outlet: 1-1/2" male NST threads. (1.990" x 9 threads per inch.)
- Consult factory for other sizes and/or threads.
- Standard inlet, outlet riser, and hub assembly are steel (also available in stainless steel).
- Rollers and roller mounting brackets are accessory items. Specify roller position.
- Pressures to 600 psi (41 bar).
- Temperatures from -25°F to +175°F (-32°C to +79°C).
- Consult factory for other pressures and temperatures.



Shown with optional polished aluminum construction

CAUTION: When using Niedner hose, a special riser and/or larger drum diameter is required.

See chart for capacity on page 20, or consult factory.

Optional

Twin Fire Reel **Conversion Kit** | For Booster Hose

For Series F and FF.

Twin booster hose reels combine matched F or FF Series reels in a single unit with a center-mounted roller and spool assembly. Hose from both reels can be used on either side of the truck. Rugged unit frame construction maintains alignment and simplifies installation when two reels are combined.

Consult dealer or factory for more information.



Two F Series reels, and a standard Twin Fire Reel Conversion Kit. Shown assembled.

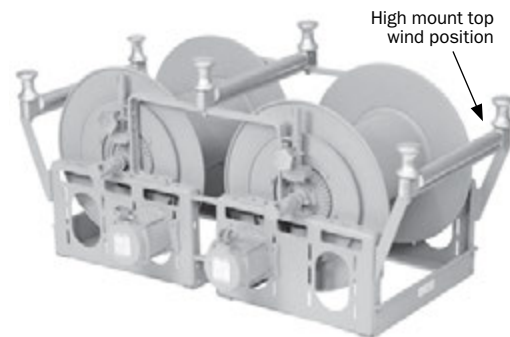

Two F Series reels, a Twin Fire Reel Conversion Kit, and two optional outrigger roller assemblies. Shown assembled.

Series FF/SBFF

• Large Diameter Booster Hose • Preconnected Collapsible Hose

PARTS DRAWING – ISO 18 PRESSED FRAME, OR ISO 41 ROLLFORM FRAME

Model Number	Hose Capacity of Reel feet m					Approx. Weight Crank Rewind lb. kg see Note 4				Reel Dimensions*** in. mm								
	Round Hose			Collapsible Hose		STEEL		ALUMINUM see Note 6		A	B	D	E	F	G	H	X	Y
	I.D. in. mm	1-1/4 32	1-1/2 38	1-1/2 38	1-3/4 44	NET	SHIP	NET	SHIP									
	O.D. in. mm	1-13/16 46	2-1/16 52	3/4 x 3 19 x 76	7/8 x 3-1/4 22 x 83													
FF28-23-24	100	50	150	125	111	153	80	122	25.5	20	20.5	23	32.25	23.5	12.12	17.5	16.75	
	30	15	46	38	50	69	36	55	648	508	521	584	819	579	308	445	425	
FF28-25-26	100	100	200	175	123	165	90	132	25.5	20	25.5	24.75	32.25	27.88	15.5	17.5	21.75	
	30	30	61	53	56	75	41	60	648	508	648	629	819	708	394	445	552	
FF16-30-31	75	50	100	75	110	160	83	133	13	7.5	25.5	28.75	19.75	29.88	15.5	7.75	21.75	
	23	15	30	23	50	73	38	60	330	191	648	730	502	759	394	197	552	
FF18-30-31	100	75	150	75	114	164	85	135	15	9.5	25.5	28.75	21.75	29.88	15.5	7	21.75	
	30	23	46	23	52	74	39	61	381	241	648	730	552	759	394	178	552	
FF28-30-31	250	150	300	250	131	181	93	143	25.5	20	25.5	28.75	32.25	29.88	15.5	17.5	21.75	
	76	46	91	76	59	82	42	65	648	508	648	730	819	759	394	445	552	
FF20-33-34	125	100	200	150	120	174	88	142	16.5	11.5	31.5	31.75	23.25	33.62	17.75	9	27.75	
	38	30	61	46	54	79	40	64	419	292	800	806	591	854	451	229	705	
FF22-33-34	150	150	250	200	125	179	91	145	18.5	13.5	31.5	31.75	25.25	33.62	17.75	11	27.75	
	46	46	76	61	57	81	41	66	470	343	800	806	641	854	451	279	705	

Notes:

- Specifications subject to change.
- Dimensions up to and including 30-31 disc size reflect pressed frames. All others are rollformed channel frames, except Super Booster®, which is square tubing.
- Upon request, reels can be supplied with drum lengths other than shown and with disc sizes in other diameters.
- Weights shown in chart are for crank rewind models. ADD these amounts for power rewind models.

	Net lbs/kg	Ship lbs/kg
Electric	40/18.1	40/18.1
Hydraulic	20/9.1	20/9.1
Air	20/9.1	20/9.1
- When ordering power rewind models, prefix model number with:
 - A** = Air Rewind – supplied with control valve and 18" air hose.
 - EP** = Electric Rewind (1/2 HP) – 12v and 24v DC rewind reels supplied with switch and solenoid. 115v AC rewind reels are not supplied with switch, but can be ordered separately.
 - HD** = Hydraulic Rewind – not supplied with control valve.
- For polished aluminum reels, prefix complete model number with "SB" (for example: SBEPFF28-23-24).
- Be sure to check dimensions and weights prior to ordering.**

NOTICE: A flexible connector must be used between the inlet pipe and the inlet swivel joint.

*** X, Y indicate mounting holes.

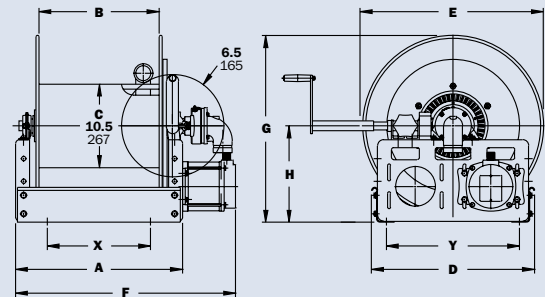

Series **F7100** | Dual Hose

• Dual Agent Applications

To handle dual 3/4" through 1-1/2" I.D. hose.

- Two swivel joint inlets and two outlet risers.
- All models are available with optional aluminum or stainless steel construction.
- Gear-driven crank rewind is standard. Choose chain and sprocket drive powered by electric, hydraulic or compressed air motor.
- Pinion brake standard.
- Standard inlet, outlet riser, and hub assembly are steel (also available in stainless steel).
- Standard inlets: 1" 90° ball bearing swivel joint, 1" female NPT threads.
- Standard outlets: 1" male NST threads (1.375" x 8 threads per inch).
- Consult factory for other sizes and/or threads.
- Pressures to 1000 psi (69 bar).
- Temperatures from -25°F to +250°F (-32°C to +121°C). Consult factory for other pressures and temperatures.
- Rollers and roller mounting brackets are accessory items. Specify roller position.

CAUTION: When using Niedner hose, a special riser and/or larger drum diameter is required (consult factory). See page 20.



SBEPF7100 Series shown
Standard configuration with optional aluminum construction.



SBEPF7100 Series shown
with optional aluminum construction and roller and spool assembly high mount

PARTS DRAWING-F7100 – ISO 72; FF7200 – ISO 74

Model Number	Hose Capacity of Reel feet m				Approx. Weight Crank Rewind lb. kg see Note 3		Reel Dimensions*** in. mm									
	I.D. in. mm	3/4 19	1 25	1-1/2 38	NET	SHIP	A	B	D	E	F CRANK	F POWER	G	H	X	Y
	O.D. in. mm	1-9/32 33	1-1/2 38	2-1/16 52												
F7126-23-24		2/75	2/50	–	109	151	23	17.5	20.5	23	32.5	34.5	23.5	12.12	15	16.75
		2/23	2/15	–	49	68	584	445	521	584	826	876	597	308	381	425
F7130-25-26		2/125	2/100	–	125	175	27.5	22	25.5	24.75	37	39	27.88	15.5	19.5	21.75
		2/38	2/31	–	57	79	699	559	648	629	940	991	708	394	495	552
F7130-30-31		2/200	2/150	–	129	179	27.5	22	25.5	28.75	37	39	29.88	15.5	19.5	21.75
		2/61	2/46	–	59	81	699	559	648	730	940	991	759	394	495	552
F7132-33-34		–	2/200	–	129	179	29	24	31.5	31.75	38.5	40.5	33.62	17.75	21.5	27.75
		–	2/61	–	59	81	737	610	800	806	978	1029	854	451	546	705

Notes:

- Specifications subject to change.
- Upon request, reels can be supplied with drum lengths other than shown and with disc sizes in other diameters.
- Weights shown in chart are for crank rewind models. ADD these amounts for power rewind models:

	Net lbs/kg	Ship lbs/kg
Electric	40/18.1	40/18.1
Hydraulic	20/9.1	20/9.1
Air	20/9.1	20/9.1

- When ordering power rewind models, prefix model number with:
 - A** = Air Rewind – supplied with control valve and 18" air hose.
 - EP** = Electric Rewind (1/2 HP) – 12v and 24v DC rewind reels supplied with switch and solenoid. 115v AC rewind reels are not supplied with switch, but can be ordered separately.
 - HD** = Hydraulic Rewind – not supplied with control valve.

- For polished aluminum reels, prefix complete model number with "SB" (for example: SBEPF 7128-23-24).
- Be sure to check dimensions and weights prior to ordering.**

NOTICE: A flexible connector must be used between the inlet pipe and the inlet swivel joint.

*** X, Y indicate mounting holes.

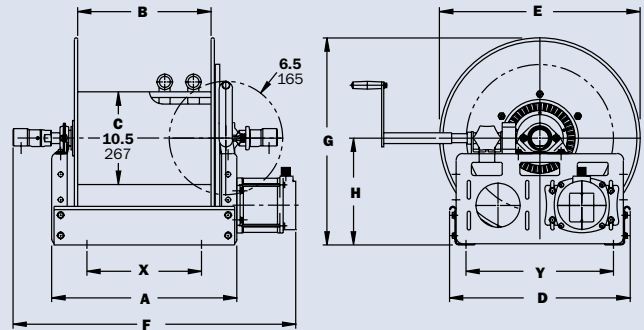

Swing-Out Reel

Booster
Hose

For Single or Dual Agent 1" through 1-1/2" I.D. hose.

Hose reels used primarily in ARFF firefighting applications. These reels mount inside truck cabinets and are designed to swing out for ease of operation and accessibility. Equipped with 2 pin locks to lock reel in stored position as well as 90° to cabinet for forward deployment of hose line.

- 12v or 24v DC explosion-proof motor.
- Heavy-duty square tubing frame.
- Auxiliary bevel gear crank rewind with pinion brake.
- Inlet 90° FxF swivel joint.
- Outlet MNST is standard (other threads available).
- Swing-out frame includes bearings and brackets for swing mount.
- Rollers available as an option.
- Grab handle is standard.
- Optional pivot release knob with multi-position lock replaces 2 manual pin locks.
- Pressures to 1000 psi (69 bar).
- Other custom sizes and configurations available depending on cabinet size.
- Right-hand version for passenger side compartment. Left-hand version for driver side compartment.
- Also usable in stored position.



Shown with optional rollers

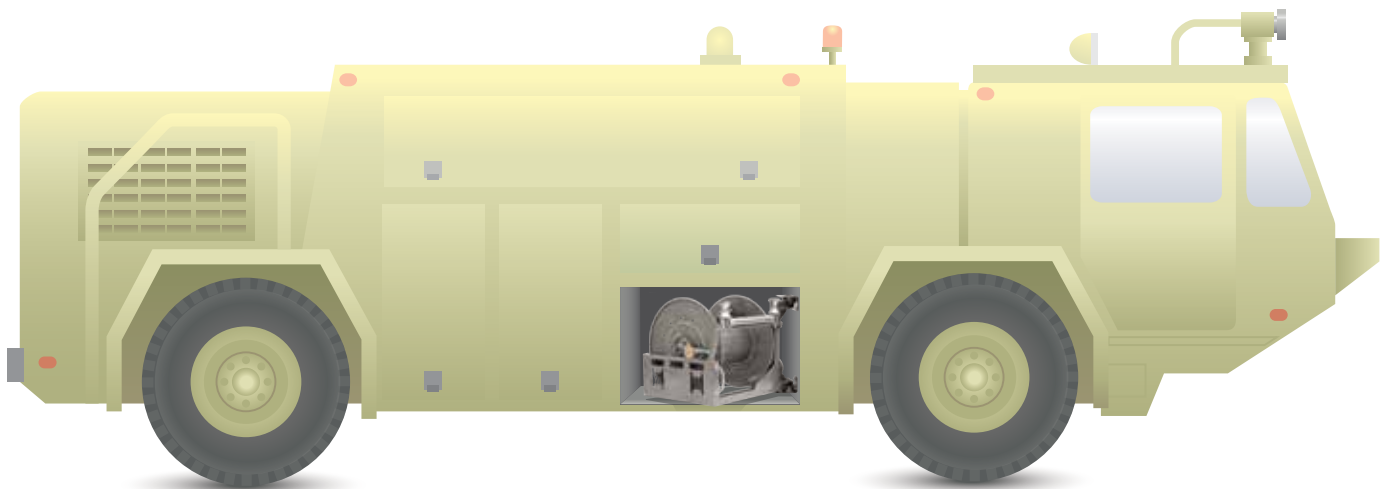

Booster
Hose

Swing-Out Reel

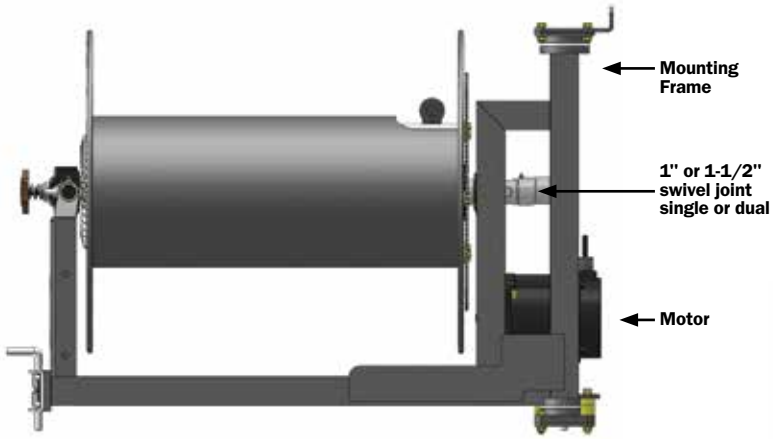

Front view in truck (stored)

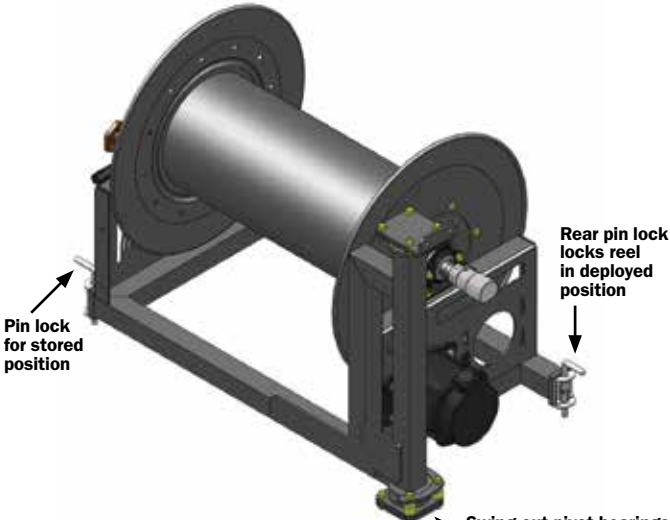

Side view in truck

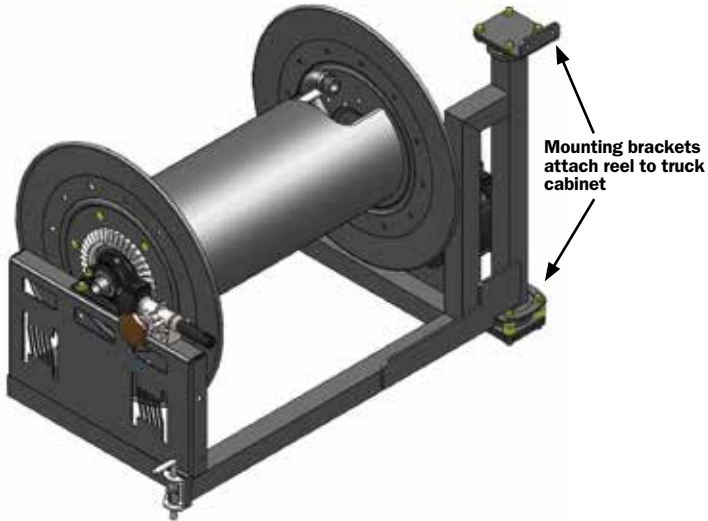

Front view - deployed

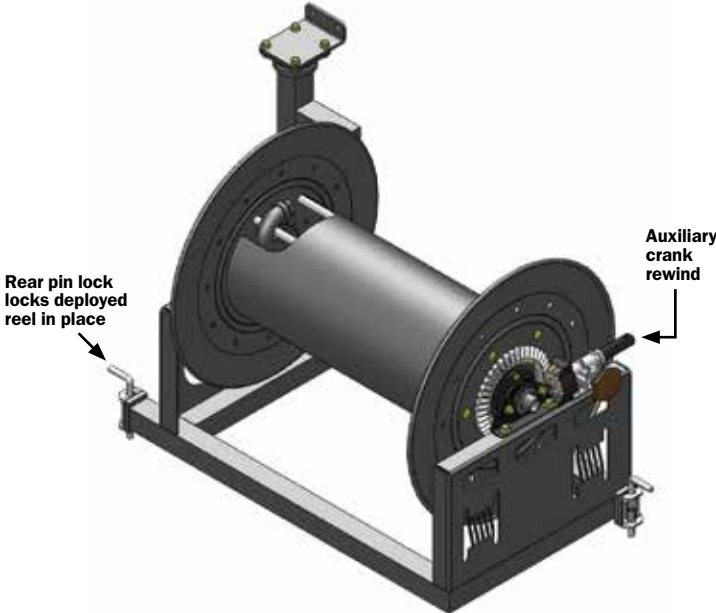

Rear view - deployed

Swing-out pivot bearings (at top and bottom) and mounting frame. Includes built-in stop to prevent over 90° rotation/deployment

Series **F3100/FF3600**

• Industrial Fire Protection

To handle 3/4" through 1-1/2" I.D. booster hose or 1" through 1-3/4" I.D. collapsible hose.

- The reel can be installed on the floor or wall.
- Steel construction is standard. Aluminum or stainless steel construction is available.
- Choose disc rewind or removable direct crank rewind.
- Supplied with spring actuated pin lock.
- Standard inlet, outlet riser, and hub assembly are steel (also available in stainless steel).
- Rollers and roller mounting brackets are accessory items. Specify roller position.

Series **F3100**

- Standard inlet: 1" 90° ball bearing swivel joint with 1" female NPT threads.
- Standard outlet: 1" male NST threads (1.375" x 8 threads per inch).
- Pressures to 1000 psi (69 bar).
- Temperatures from -25°F to +225°F (-32°C to +121°C).

Series **FF3600**

- Standard inlet: 1-1/2" 90° ball bearing swivel joint with 1-1/2" female NPT threads and 2" Victaulic® groove.
- Standard outlet: 1-1/2" male NST threads (1.990" x 9 threads per inch).
- Pressures to 600 psi (41 bar).
- Temperatures from -25°F to +175°F (-32°C to +79°C).

Both Series

- Consult factory for other sizes and/or threads.
- Consult factory for other pressures and temperatures.
- Removable crank rewind is standard.
- For hand over hand rewind option (less crank), consult factory.

CAUTION: When using Niedner hose, a special riser and/or larger drum diameter is required (consult factory). See page 20.



F3100 Series shown
Standard configuration



FF3600 Series shown
Standard configuration

Series F3100/FF3600

• Industrial Fire Protection

PARTS DRAWING – F3100 – ISO 113; FF3600 – ISO 111

Model Number	Hose Capacity of Reel feet m				Approx. Weight Crank Rewind lb. kg		Reel Dimensions*** in. mm							
	Round Hose		Collapsible Hose				NET	SHIP	A	B	D	E	F	G
	I.D. in. mm	3/4 19	1 26											
	O.D. in. mm	1-9/32 33	1/2 x 1-3/4 13 x 44											
F3116-25-26		100	200		85	120	13	7.5	25.5	24.75	25.5	27.88	15.5	7.75
		30	61		39	54	330	191	648	629	648	708	394	197
F3120-25-26		150	350		94	129	17	11.5	25.5	24.75	29.5	27.88	15.5	9
		46	107		43	59	432	292	648	629	749	708	394	229
F3124-25-26		200	450		103	138	21	15.5	25.5	24.75	33.5	27.88	15.5	13
		61	137		47	63	533	394	648	629	851	708	394	330
F3128-25-26		275	650		113	155	25.5	20	25.5	24.75	37	27.88	15.5	17.5
		84	198		51	70	648	508	648	629	940	708	394	445
F3124-30-31		350	-		103	153	21	15.5	25.5	28.75	33.5	29.88	15.5	13
		107	-		47	70	533	394	648	730	851	759	394	330
F3130-30-31		450	-		113	143	27.5	22	25.5	28.75	40	29.88	15.5	19.5
		137	-		51	65	699	559	648	730	1016	759	394	495

Model Number	Hose Capacity of Reel feet m				Approx. Weight Crank Rewind lb. kg		Reel Dimensions*** in. mm							
	Round Hose		Collapsible Hose				NET	SHIP	A	B	D	E	F	G
	I.D. in. mm	1-1/2 38	1-1/2 38	1-3/4 44										
	O.D. in. mm	2-1/16 52	3/4 x 3 19 x 76	7/8 x 3-1/4 22 x 83										
FF3620-25-26		75	150	75	104	139	17	11.5	25.5	24.75	30.75	27.88	15.5	9
		23	46	23	47	63	432	292	648	629	781	708	394	229
FF3624-25-26		75	150	100	113	148	21	15.5	25.5	24.75	34.75	27.88	15.5	13
		23	46	30	51	67	533	394	648	629	883	708	394	330
FF3628-25-26		100	200	150	123	173	25.5	20	25.5	24.75	39.25	27.88	15.5	17.5
		30	61	46	56	78	648	508	648	629	997	708	394	445
FF3624-30-31		100	250	150	124	174	21	15.5	25.5	28.75	34.75	30.38	15.5	13
		30	76	46	56	79	533	394	648	730	883	772	394	330
FF3628-30-31		150	300	250	134	184	25.5	20	25.5	28.75	39.25	30.38	15.5	17.5
		46	91	76	61	83	648	508	648	730	997	772	394	445
FF3634-30-31		200	400	350	147	197	31.5	26	25.5	28.75	45.25	30.38	15.5	23.5
		61	122	107	67	89	800	660	648	730	1149	772	394	597
FF3630-33-34		250	450	350	138	188	27.5	22	25.5	31.75	41.25	32.38	16.5	19.5
		76	137	107	63	85	699	559	648	806	1048	822	419	495

Notes:

- Specifications subject to change.
- Upon request, reels can be supplied with drum lengths other than shown and with disc sizes in other diameters.
- Power rewind is not available on these models. See Series F or FF.
- 4" clearance needed for crank handle removal.
- Be sure to check dimensions and weights prior to ordering.**

NOTICE: A flexible connector must be used between the inlet pipe and the inlet swivel joint.
***X, Y indicate mounting holes.

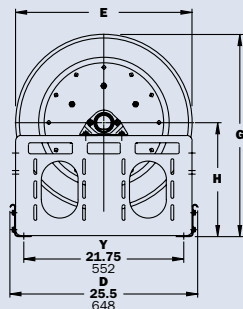

F3100

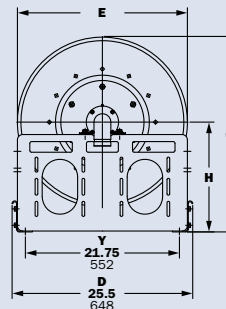
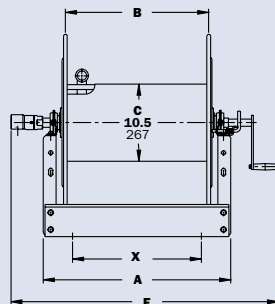

FF3600

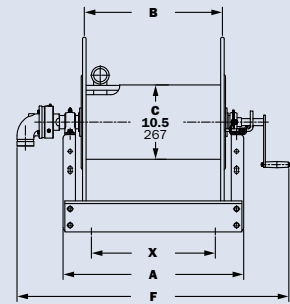

Series LD Reels and Spools | Large Diameter

Reels and spools to handle up to 6" I.D. collapsible hose.

Typical Installations:

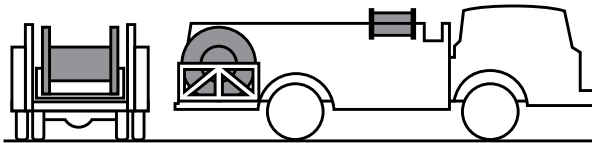

Single large-capacity reel installed in the hose bed area to handle long lengths of pre-coupled hose. Hose pays out from the top of the reel so gravity assists unwinding.

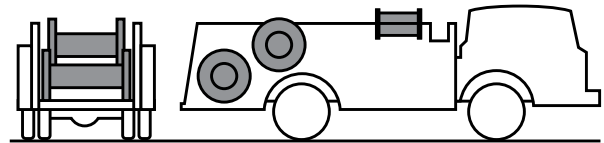

Two reels installed in the hose bed. In this arrangement, the upper reel is unloaded only if necessary. Payout and rewinding of the upper reels are facilitated by the position of the lower reel. Two reels with larger-diameter discs and narrower drums can also be installed side-by-side in the rear of the hose bed to handle approximately the same amount of hose. This method allows a center walkway or paying out two lines simultaneously if required.

- Square tubing frames.
- Heavy-gauge steel discs.
- Drums are formed by reinforced tie rods with radial supports.
- Pillow block ball bearings.
- Chain and sprocket rewind with electric (12v or 24v) or hydraulic rewind motor.
- Hydraulic caliper disc brake.

Hydraulic Requirements

- It is important that the end-user provide Hannay Reels with complete specifications as to the required operation of the large diameter reel being specified. Any speed and torque requirements **MUST** be known to properly specify the correct reel for the application.
- Hannay Reels does not recommend specific brands for hydraulic system components. We suggest you work with your hydraulic component supplier to meet your specs.

Custom Reels

- The standard models listed represent the most frequently specified customer requirements for handling large-diameter fire hose. Because of the many possible variations in reel installation and hose capacity requirements, we will also custom build reels and spools to your specifications to become an integral part of the apparatus. Reels are built of steel construction, and various finishes are available.

Consult factory for complete specifications on an LD reel to meet your requirements.

Important: Hose capacity is based on the flat hose dimensions listed below, with couplings at 100 foot intervals.

Flat Hose Dimensions

I.D.	Thick x Width	
	in	mm
1"	1/2 x 1-3/4	12.7 x 44.4
1-1/2"	3/4 x 3	19.0 x 76.2
1-3/4"	7/8 x 3-1/4	22.2 x 79.4
2"	3/4 x 3-1/2	19.0 x 88.9
2-1/2"	3/4 x 4	19.0 x 101.6
3"	1/2 x 5	12.7 x 127.0
4"	1/2 x 6-1/2	12.7 x 165.1
5"	1/2 x 8	12.7 x 203.2
6"	1/2 x 10	12.7 x 254.0

Custom sizes are available to meet specific needs.

Large Diameter

Series LD Reels and Spools

Configurations

PARTS DRAWING – ISO 104

Model Number	Hose Capacity of Reel feet m										Approx. Weight (Steel) Crank Rewind lb. kg		Reel Dimensions in. mm						
	I.D. in. mm	1-1/2 38	1-3/4 44	2 51	2-1/2 64	3 76	4 102	5 127	6 152	NET	SHIP	A HYD REWIND	A ELECT REWIND	B	D	E	G	H	
LD268-30	800	600	600	600	600	600	500	250	-	370	450	65.5	63	54	30.5	30	39	24	
	244	183	183	183	183	183	152	76	-	168	204	1664	1600	1372	775	762	991	610	
LD268-33	1000	700	800	700	800	600	350	-	385	465	65.5	63	54	33.5	33	42	25.5		
	305	213	244	213	244	183	107	-	175	211	1664	1600	1372	851	838	1067	648		
LD234-39	-	400	350	350	400	300	200	-	365	465	31.5	29	20	39.5	39	45	25.5		
	-	122	107	107	122	91	61	-	166	211	800	737	508	1003	991	1143	648		
LD242-39	-	500	600	500	500	400	300	-	381	481	39.5	37	28	39.5	39	45	25.5		
	-	152	183	152	152	122	91	-	173	218	1003	940	711	1003	991	1143	648		
LD262-39	-	-	-	-	1100	800	600	-	421	521	59.5	57	48	39.5	39	45	25.5		
	-	-	-	-	335	244	183	-	191	236	1511	1448	1219	1003	991	1143	648		
LD274-39	-	-	-	-	-	1050	800	-	445	545	71.5	69	60	39.5	39	45	25.5		
	-	-	-	-	-	320	244	-	202	247	1816	1753	1524	1003	991	1143	648		
LD242-45	-	-	-	-	-	500	400	-	427	557	40	-	28	45.5	45	51	28.5		
	-	-	-	-	-	152	122	-	194	253	1016	-	711	1156	1143	1295	724		
LD262-45	-	-	-	-	-	1100	900	-	467	597	60	-	48	45.5	45	51	28.5		
	-	-	-	-	-	335	274	-	212	271	1524	-	1219	1156	1143	1295	724		
LD274-45	-	-	-	-	-	1400	1100	-	491	621	72	-	60	45.5	45	51	28.5		
	-	-	-	-	-	427	335	-	223	282	1829	-	1524	1156	1143	1295	724		
LD242-52	-	-	-	-	-	800	500	300	581	731	40	-	28	52.5	52	58	32		
	-	-	-	-	-	244	152	91	264	332	1016	-	711	1334	1321	1473	813		
LD262-52	-	-	-	-	-	1500	1300	800	621	771	60	-	48	52.5	52	58	32		
	-	-	-	-	-	457	396	244	282	350	1524	-	1219	1334	1321	1473	813		
LD274-52	-	-	-	-	-	2000	1500	1200	645	795	72	-	60	52.5	52	58	32		
	-	-	-	-	-	610	457	366	283	361	1829	-	1524	1334	1321	1473	813		
LD250-56	-	-	-	-	-	1300	1000	700	657	817	48	-	36	56.5	56	62	34		
	-	-	-	-	-	396	305	213	298	371	1219	-	914	1435	1422	1575	864		
LD262-56	-	-	-	-	-	1800	1500	900	681	841	60	-	48	56.5	56	62	34		
	-	-	-	-	-	549	457	274	309	381	1524	-	1219	1435	1422	1575	864		
LD274-56	-	-	-	-	-	2300	1700	1400	705	865	72	-	60	56.5	56	62	34		
	-	-	-	-	-	701	518	427	320	392	1829	-	1524	1435	1422	1575	864		
LD350-64	-	-	-	-	-	1700	1300	900	1130	1330	50.25	-	36	64.75	64	70	38		
	-	-	-	-	-	518	396	274	513	603	1276	-	914	1645	1626	1778	965		
LD374-64	-	-	-	-	-	3000	2000	1900	1200	1400	74.25	-	60	64.75	64	70	38		
	-	-	-	-	-	914	610	579	544	635	1886	-	1524	1645	1626	1778	965		

Electric rewind not available on these models

Version F Reel:

Complete reel assembly with No. 50 chain and sprocket and hydraulic rewind motor mounted inside the frame. When ordering, use prefix model number with HD (for example: HDLD 350-64 version F).

Version G Reel:

(High profile) complete reel assembly with chain and sprocket drive and electric rewind motor, including clutch and double reduction unit. Motor is mounted inside the frame. Disc diameters (E dimension) up to and including 39" only. When ordering, use prefix model number with EP (for example: EPLD 242-39 version G). "F" dimension = "A" dimension +5".

Notes:

1. Specifications subject to change.
2. Upon request, reels can be supplied with drum lengths other than shown and with disc sizes in other diameters.
3. Be sure to check dimensions and weights prior to ordering.

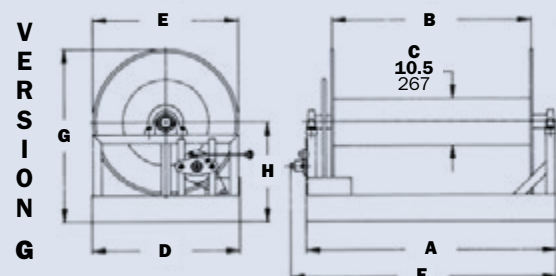
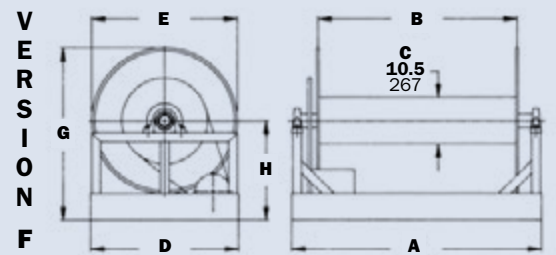

Mercedes and Niedner Capacities

Mercedes Hose

Reel Model Number	Hose Capacity of Reel feet m				Approx. Weight lb. kg				Reel Dimensions*** in. mm									
	I.D. in. mm	3/4 19	1 25	1-1/2 38	STEEL		ALUMINUM		A	B	C	D	E	F POWER	G	H	X	Y
	O.D. in. mm	1.062 27	1.281 33	1.812 46	NET	SHIP	NET	SHIP										
F4024-17-18	100	-	-	-	46	81	-	-	21	16	8	14.5	19	27	18.12	9.88	19.5	10
	30	-	-	-	21	37	-	-	533	406	203	368	483	686	460	251	495	254
F4030-17-18	200	-	-	-	57	92	-	-	27	22	8	14.5	19	33	18.12	9.88	25.5	10
	61	-	-	-	26	42	-	-	686	559	203	368	483	838	460	251	648	254
F4124-17-18	100	-	-	-	72	107	-	-	21	16	8	15.5	20.5	27.5	18.12	9.88	13.5	12.25
	30	-	-	-	33	49	-	-	533	406	203	394	521	699	460	251	343	311
F4130-17-18	200	-	-	-	83	118	-	-	27	22	8	15.5	20.5	33.5	18.12	9.88	19.5	12.25
	61	-	-	-	38	54	-	-	686	559	203	394	521	851	460	251	495	311
*F32-19-21	175	150	-	-	102	144	80	122	29.5	24	10.5	20.5	21.62	34.38	21.5	12.12	21.5	16.75
	53	46	-	-	46	65	36	55	749	610	267	521	549	873	546	308	546	425
*F24-23-24	200	150	-	-	92	134	75	117	21	15.5	10.5	20.5	23	25.88	23.5	12.12	13	16.75
	61	46	-	-	42	61	34	53	533	394	267	521	584	657	597	308	330	425
*F30-23-24	300	200	-	-	105	147	82	124	27.5	22	10.5	20.5	23	32.38	23.5	12.12	19.5	16.75
	91	61	-	-	48	67	37	56	699	559	267	521	584	822	597	308	495	425
*F16.5-30-31	200	150	-	-	100	150	80	130	13.5	8	10.5	25.5	28.75	18.38	29.88	15.5	5.5	21.75
	61	46	-	-	45	68	36	59	343	203	267	648	730	467	759	394	140	552
*F20-30-31	300	200	-	-	107	157	83	133	17	11.5	10.5	25.5	28.75	21.88	29.88	15.5	9	21.75
	91	61	-	-	49	71	38	60	432	292	267	648	730	556	759	394	229	552
FF32-30-31-20	-	-	100	-	138	188	100	150	29.5	24	20	25.5	28.75	36.25	29.88	15.5	21.5	21.75
	-	-	30	-	63	54	45	68	749	610	508	648	730	921	759	394	546	552
FF34-33-34-20	-	-	200	-	140	194	106	160	31	26	20	31.5	31.75	37.75	33.62	17.75	23.5	27.75
	-	-	61	-	64	88	48	73	787	660	508	800	806	959	854	451	597	705

Niedner Hose

Reel Model Number	Hose Capacity of Reel feet m				Approx. Weight lb. kg				Reel Dimensions*** in. mm									
	I.D. in. mm	3/4 19	1 25	1-1/2 38	STEEL		ALUMINUM		A	B	C	D	E	F POWER	G	H	X	Y
	O.D. in. mm	1.075 27	1.325 34	1.825 46	NET	SHIP	NET	SHIP										
*F28-19-21-10.5	100	-	-	-	98	140	76	118	25.5	20	10.5	20.5	21.62	30.25	21.5	12.12	17.5	16.75
	30	-	-	-	44	64	34	54	648	508	267	521	549	768	546	308	445	425
*F26-23-24-10.5	200	-	-	-	94	136	71	113	23	17.5	10.5	20.5	23	27.88	23.5	12.12	15	16.75
	61	-	-	-	43	62	32	51	584	445	267	521	584	708	597	308	381	425
*F24-23-24-12	-	100	-	-	92	134	75	117	21	15.5	12	20.5	23	25.88	23.5	12.12	13	16.75
	-	30	-	-	42	61	34	53	533	394	305	521	584	657	597	308	330	425
F28-25-26-12	-	200	-	-	113	155	87	129	25.5	20	12	25.5	24.75	32.25	27.88	15.5	17.5	21.75
	-	61	-	-	51	70	39	59	648	508	305	648	629	819	708	394	445	552
FF32-30-31-20	-	-	100	-	138	188	100	150	29.5	24	20	25.5	28.75	36.25	29.88	15.5	21.5	21.75
	-	-	30	-	63	54	45	68	749	610	508	648	730	921	759	394	546	552
FF34-33-34-20	-	-	200	-	140	194	106	160	31	26	20	31.5	31.75	37.75	33.62	17.75	23.5	27.75
	-	-	61	-	64	88	48	73	787	660	508	800	806	959	854	451	597	705

Notes:

1. Specifications subject to change.
2. These reels require a special angle riser and larger diameter drum; consult factory.
3. For F Series – Refer to notes and diagram on page 7.
4. For FF Series – Refer to notes and diagram on page 11.

NOTICE: A flexible connector must be used between the inlet pipe and the inlet swivel joint.
 *The "F" dimension for these models is shown for 1/3 HP motors. Add 2" to "F" dimension for 1/2 HP motors. The "F" dimension for all other reels is shown for 1/2 HP. Reels handling 200' or more must use 1/2 HP motor. (Use prefix EP when ordering.)
 *** X, Y indicate mounting holes.

Hannay Reels Versatility

Firefighting and rescue operations around the country depend on the versatility of Hannay Reels.

For decades, Hannay Reels has set the standard of quality and reliability for hose reels in the firefighting industry.

But as the needs of the industry change, so do our reels. Hannay prides itself on being able to conform to new standards required by the firefighting industry – reels that fit into side compartments or bumper mounts, open reel installation or swing-out reels for easy, quick access.



Through research and development of internationally recognized standard models, to custom one-of-a-kind applications, Hannay continues to meet the specific needs of the vehicle or individual fire department.

In supplying both apparatus manufacturers and aftermarket fire departments worldwide, Hannay has consistently serviced the needs of the industry. With Hannay reels, there's no draining, stacking or dragging. Plus, firefighters appreciate quick attack and fast pick-up.



**What size reel
can we build for you?**



Hannay Reels **Sales Policies**

Hannay Reels 3-Year Limited Warranty

Products manufactured by Hannay Reels, Inc. (“Hannay”) are warranted for 3 years from date of shipment when properly installed, maintained, and operated in accordance with Hannay instructions. In no event will Hannay have a warranty obligation for normal wear and tear, or for products that have, at Hannay’s determination, been subjected to accident, abuse, misapplication, improper installation or improper maintenance. Common examples of normal wear and tear would include paint finish, swivel joint seal wear, and switch or motor brush wear.

Hannay makes no warranties, express or implied, other than those included in this warranty statement, and we disclaim any implied warrant of merchantability or fitness for any particular purpose. Hannay will not be liable for any consequential, incidental, or indirect damages from any cause whatsoever.

Failure to use a flexible inlet connection on any live hose reel will void the swivel joint warranty. Failure to use a properly sized circuit breaker with any electric rewind motor will void the electric motor warranty. Failure to use a filter and lubricator on any air rewind motor will void the air motor warranty. Failure to follow all procedures outlined in the Safety Guidelines document will void the warranty.

Components not manufactured by Hannay will be subject to the original manufacturers’ warranties. Examples of such components include: hose and cable, motors, speed controls, and switches, swivel joints and seals, slip ring and brush assemblies.

Equipment which proves to be defective upon our inspection will be replaced free of charge, including freight to the customer. Our responsibility ceases upon delivery to any common carrier and we do not, unless previously instructed, insure shipments beyond point of delivery to such carrier. **No material will be accepted for return without a return goods authorization (RGA).** This warranty extends to the replacement or repair of the reel or part (no labor).

Hannay reserves the right to modify or alter materials, dimensions, design, and construction when necessary to improve the performance of the reel and/or accessories, or to meet delivery requirements.

Notice on Reel Finish

Standard finish on Hannay reels is a high performance modified acrylic enamel paint. Standard color is metallic graphite. Other colors available at no additional cost include red, white, black, and primer.

Most of the major components on standard reels are e-coated prior to receiving final topcoat paint finish. This combination of e-coat and enamel topcoat will meet the finish requirements of most customer applications and environments.

In cases where requirements cannot be met with the standard finish, Hannay Reels can coat any model reel with an automotive primer, allowing application of final coating at your facility. Alternatively, Hannay Reels can provide a quote for matching a customer-provided paint specification. For further information, please contact your Hannay Reels sales engineer and a special paint request form will be sent to you.

For environments where no paint finish is suitable, we offer both aluminum and stainless steel (304 grade) construction on most reel models.

Return Goods Policy

All Hannay reels are built to order. These orders are typically placed into production within 1 business day of receipt. Once production begins, it may not be possible to cancel the order.

To prevent returns because the wrong reels or parts were ordered, please use the Hannay Reels Spec Worksheet (either online or from our Order Accessory Guide) when specifying reels. Be sure to include any size, weight, pressure and/or material compatibility limitations for the application.

In the event that an item does need to be returned for credit, repair or replacement, prior approval must be obtained from Hannay Reels. Upon your request, we will send a Return Goods

Authorization (RGA) form. A signed copy of this form must accompany the material when returned to us, with the RGA number clearly showing on the outside of the box—a label is provided to you that you can print and attach. No product will be accepted for return or credit without an authorized RGA number.

All material must be returned prepaid, unless otherwise noted on our RGA. No return will be accepted that has been damaged due to improper return packaging, tampered with or altered from its original condition. Our restocking and handling fee is a minimum of 25% for standard catalog reels and parts. Custom reels specially built to customer specifications cannot be returned for any reason.

Hose Reel **Spec Worksheet**

To specify Hannay reels, fill out this simple form and mail, fax or email it to your dealer.
Photocopy this page or download and print from hannay.com

1. Who is the reel for?

Contact		Date / /	
Company		Position	
Street Address			
City	State	Zip	Country
Phone ()	Fax ()	Email	

2. What is the reel for?

HOSE (check one): Storage only Live Single hose Live Dual hose

Inside diameter:	Hose length:	Bend radius:	Flat hose dimensions:
Outside diameter:	Hose weight:	Coupling spacing:	

Type of product handled live application (check one):

<input type="radio"/> Liquid (specify):	<input type="radio"/> Temperature:	<input type="radio"/> Oxygen/Acetylene:	<input type="radio"/> Other (specify):
<input type="radio"/> Gases (specify):	<input type="radio"/> Pressure:	<input type="radio"/> Hydraulic fluid (specify):	

Fluid path type (check one): Steel (standard) Aluminum Stainless Steel Other

Reel inlet type (check one): Swivel joint 90° (standard) Straight

Reel outlet type (riser): Size:

Thread (check one):	<input type="radio"/> National Pipe Thread (NPT)	<input type="radio"/> Joint Industry Committee (JIC)	<input type="radio"/> Other (specify):
	<input type="radio"/> National Standard Thread (NST)	<input type="radio"/> British Standard Pipe (BSP)	

3. What features does the reel need? Check type of rewind:

MANUAL REWIND

Disc rewind (hand over hand) Gear-driven crank Direct crank (permanent or removable) Chain-driven crank

POWER REWIND

Spring Air Electric (voltage): Hydraulic

Type of installation (check one): Floor Wall Overhead Vehicle

Temperature Range:	Environment:
Accessories (if any):	Hose Stop: <input type="radio"/> Yes <input type="radio"/> No

Roller Assemblies:

Finish: Painted steel (standard) Aluminum Polished Unpolished Stainless steel Polished Unpolished

Check type of installation and roller position for spring reels:

Drag Position SR Lift Position VR Stretch (no roller) Position TR Wall Mount Position TR Recovery (pick-up) (no roller)

Constant tension available on all roller positions

Indicate your custom specifications

4. Specifying Location of Components

Optional Location of Components:

Location of the inlet, outlet riser, and rewind mechanism can be varied to meet your requirements and **must be specified on your order**. Unless otherwise specified, most reels will be shipped as **Right Top Rewind** with the inlet, outlet riser, and rewind mechanism on the operator's right.



RT - Right Top Rewind
Standard - Always look at your reel from this position to determine right hand or left hand.



RB - Right Bottom Rewind



LT - Left Top Rewind



LB - Left Bottom Rewind

Note: Use component location initials as suffix after model number (ie: EF32-23-24 RT)

5. Please note size and/or weight limitations for your installation

SPECIFICATIONS

Depth: _____

Height: _____

Width: _____

Weight: _____

For custom applications not found in our catalogs, call the Inside Sales Group at 518-797-3791.

You Can't Buy A Better Reel.

Find reels for every need.

Learn more about all of our reels, including specs, drawings, and even how to select the right reels and accessories for your industry.

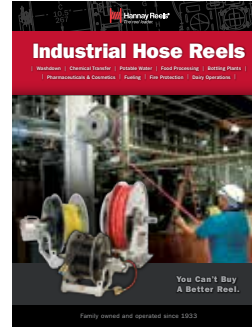

Only one reel is built strong to last long.

Our reels are custom designed to meet your unique specs, never retrofitted to the job. So no matter how small the footprint, you can expect superior performance every time. And we only use high quality, heavy-duty materials – never plastic – which is why our reels often outlast the vehicles they're on. For reels that outlast and outperform all the others, you can depend on Hannay, the leader in OEM, industrial, and commercial reel applications.

Rescue Reels

Details on:

- Utility or breathing air hose reels
- Live electric cable reels
- Power rescue tool reels
- Portable electric cable reels

Hose Reels

Includes specs and information on:

- High pressure spring rewind reels
- Compact manual rewind reels
- Power rewind reels
- Portable storage reels
- Hose assemblies

Cable Reels

Find out more about:

- Manual and power rewind reels
- Storage reels
- Reels for live electric cable
- Portable reels
- Static and truck grounding reels

View all our reel catalogs online at hannay.com



Family owned and operated since 1933, Hannay Reels is the world leader in both OEM and aftermarket applications. Hannay offers thousands of standard hose reel and cable reel models, as well as unmatched custom capabilities. We can easily and affordably customize a reel to meet your exact specifications – built to last, delivered fast. Additional catalogs are available through your local Hannay Reels dealer or online at hannay.com.



553 State Route 143 | Westerlo, New York 12193
Email: reels@hannay.com | hannay.com



All Hannay reels are constructed of quality heavy gauge steel (optional aluminum or stainless steel also available on most models).

Phone: 518-797-3791
Toll Free: 1-877-467-3357

Domestic FAX: 1-800-733-5464
International FAX: 518-797-3259

Form H-0502-F Rev 4 WEB 1-18



Reel Product News

Portable Reels for 1" Forestry and Standard Lay Flat Hose

Hannay Reels offers two lightweight and portable hose storage reels – ideal for Forestry lay flat or Standard lay flat hose – when extra lengths are needed in an emergency.

Model C16-10-11

- Small, lightweight, durable.
- Adjustable cam-lock drag brake.
- Permanent crank rewind.
- For forestry lay flat hose, extension cord or rope.



Model C16-10-11
shown with optional red finish

Model C20-14-16

- Strong, portable.
- Adjustable cam-lock drag brake.
- Permanent crank rewind.
- Optional pin lock available.
- For forestry lay flat hose, standard lay flat hose, extension cord or rope.



Model C20-14-16
shown with optional red finish

Parts Drawing – Model C16-10-11 – ISO 88; Model C20-14-16 – ISO 121

Model Number	Hose Capacity of Reel			Approx. Weight		Reel Dimensions							
	feet		m			in. mm							
	I.D. in. mm	Forestry Lay Flat 1 25	Standard Lay Flat 1 25	NET	SHIP	A	B	C	D	E	F	G	H
C16-10-11	100	–	–	10	17*	–	7.5	4	11.88	10.75	12.25	14.75	6.88
	30	–	–	5	8	–	191	102	302	273	311	375	175
C20-14-16	200	100	18	58*	15	12	6	15.5	14	16.75	19	8.62	
	61	30	8	26	381	305	152	394	356	425	483	219	

Notes:

1. Specifications subject to change.
2. These storage reels have no live connections.

3. Be sure to check dimensions and weights prior to ordering.

*Dimensional weight applies when shipped as a parcel package (via FedEx or UPS Ground).

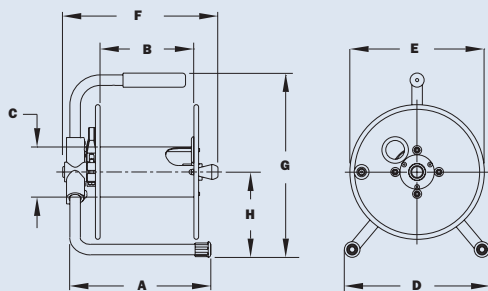

Model C16-10-11

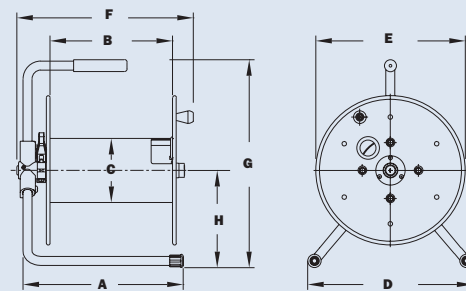

Model C20-14-16